

Werkzeuge für Maschine

Tools for machine

Outils pour machine

Daewoo

Puma (BMT 65)

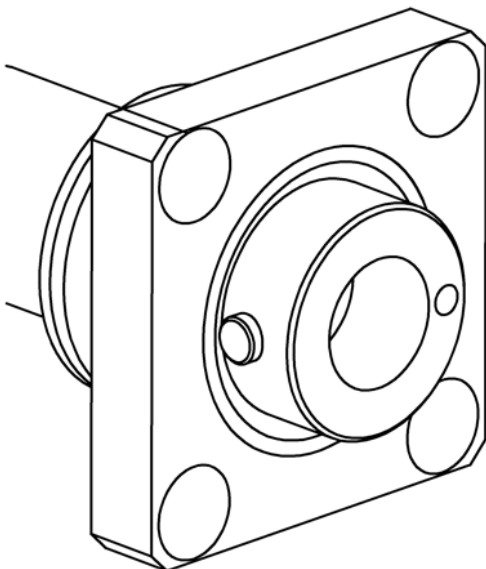
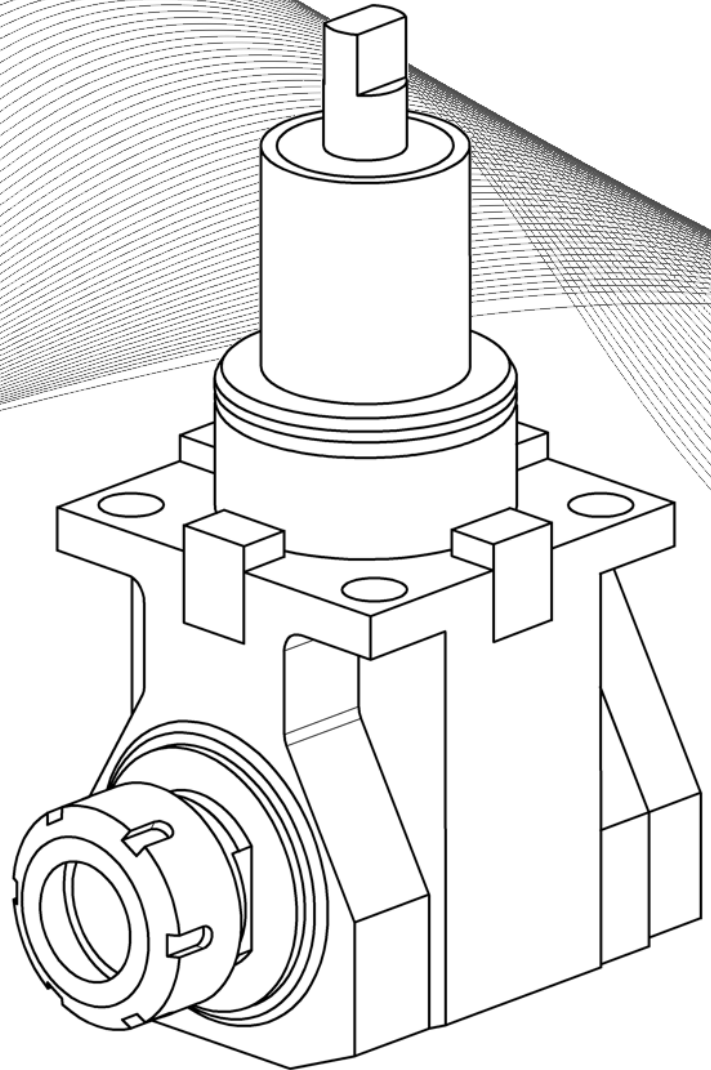

Axial- Bohr- und Fräskopf

Axial drilling and milling head

Tête de perçage et de fraisage axiale

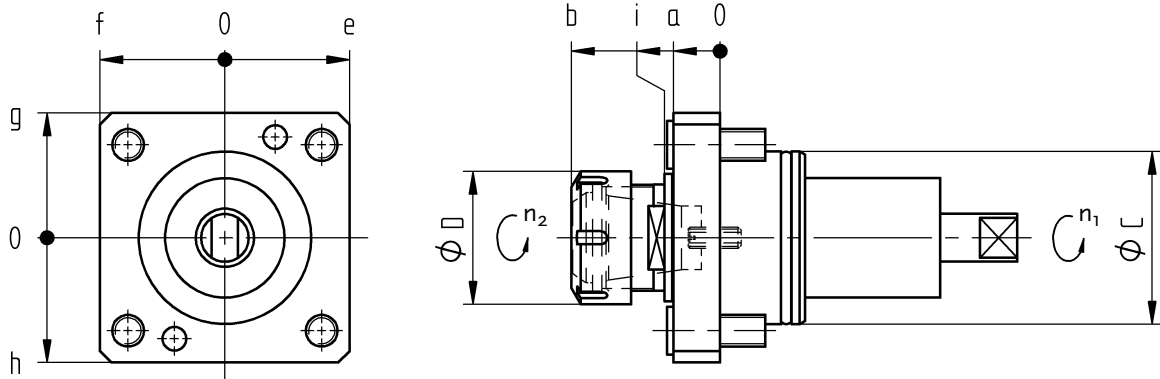

Interne Kühlmittelzufuhr: Angaben unter „IK“ in Tabelle mit Diagramm „D oo ...“ beachten
for internal coolant supply: Please note the diagram „D oo ...“ which is mentioned in the table below in the column named „IK“
pour arrosage interne: voir le diagramme „D oo ...“ mentioné dans la colonne „IK“ du tableau ci-dessous

$$i = 1:1$$

$$M_{\max} = 50 \text{ Nm}$$

$$n_1 = +n_2 \quad n_{\max} = 6000 \text{ min}^{-1}$$

Spannzangenaufnahme

collet chuck

porte pince

Bestell-Nr. ref.-no. no. de cde.	Werkzeugaufnahme clamping application attachement outil	IK D oo ...	p _{max} [bar]	a [mm]	b [mm]	øC [mm]	øD [mm]	e [mm]	f [mm]	g [mm]	h [mm]	i [mm]
8 010 66 027	DIN 6499-ER 32	-	-	17,5	56	65	50	47	47	47	47	47
8 010 66 028	DIN 6499-ER 32	... oo?	25	17,5	56	65	50	47	47	47	47	47



ZB 655 ...*



ZB ER ...*



ZB ET ...*



ZB 741 ...*



Darstellung symbolisch
symbolical drawing
schéma symbolique

*** nicht im Lieferumfang enthalten**
not included in delivery
non compris dans la livraison

Axial- Bohr- und Fräskopf

Axial drilling and milling head

Tête de perçage et de fraisage axiale

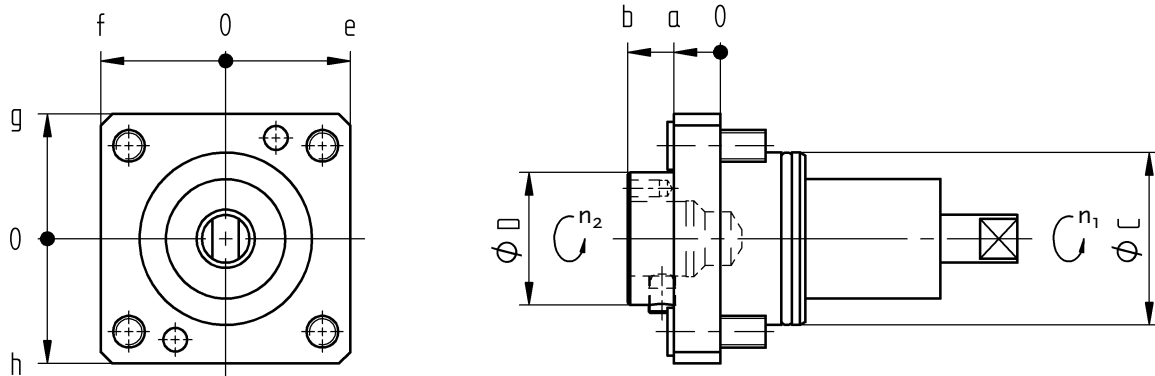

Interne Kühlmittelzufuhr: Angaben unter „IK“ in Tabelle mit Diagramm „D oo ...“ beachten
for internal coolant supply: Please note the diagram „D oo ...“ which is mentioned in the table below in the column named „IK“
pour arrosage interne: voir le diagramme „D oo ...“ mentioné dans la colonne „IK“ du tableau ci-dessous

$$i = 1 : 1$$

$$M_{\max} = 50 \text{ Nm}$$

$$n_1 = +n_2 \quad n_{\max} = 6000 \text{ min}^{-1}$$

easy-quick

easy-quick

easy-quick

Bestell-Nr. ref.-no. no. de cde.	Werkzeugaufnahme clamping application attachment outil	IK D oo ...	p _{max} [bar]	a [mm]	b [mm]	øC [mm]	øD [mm]	e [mm]	f [mm]	g [mm]	h [mm]
8 010 67 025	easy-quick HT 5	-	-	17,5	35	65	50	47	47	47	47
8 010 67 026	easy-quick HT 5	... oo?	25	17,5	35	65	50	47	47	47	47



ZB 655 ...*



ZB HT ...*



Darstellung symbolisch
symbolical drawing
schéma symbolique

*** nicht im Lieferumfang enthalten**
not included in delivery
non compris dans la livraison

Winkel- Bohr- und Fräskopf

Radial drilling and milling head

Tête de perçage et de fraisage radiale

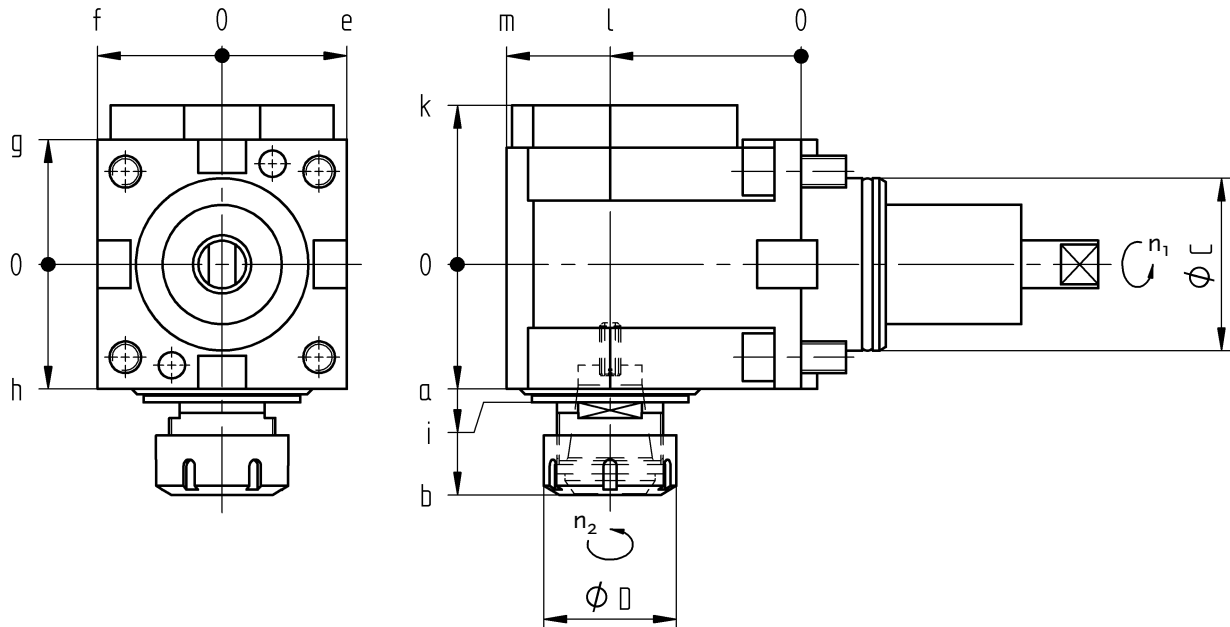

Interne Kühlmittelzufuhr: Angaben unter „IK“ in Tabelle mit Diagramm „D oo ...“ beachten
for internal coolant supply: Please note the diagram „D oo ...“ which is mentioned in the column named „IK”

pour arrosage interne: voir le diagramme „D oo ...” mentioné dans la colonne „IK” du tableau ci-dessous

$$i = 1 : 1$$

$$M_{\max} = 50 \text{ Nm}$$

$$n_1 = +n_2$$

$$n_{\max} = 6000 \text{ min}^{-1}$$

Spannzangenaufnahme

collet chuck

porte pince

Bestell-Nr. ref.-no. no. de cde.	Werkzeugaufnahme clamping application attachment outfl	IK D oo ...	p _{max} [bar]	a [mm]	b [mm]	øC [mm]	øD [mm]	e [mm]	f [mm]	g [mm]	h [mm]	i [mm]	k [mm]	l [mm]	m [mm]
8 030 66 029	DIN 6499-ER 32	-	-	47	87	65	50	47	47	47	47	52	50	72	111
8 030 66 030	DIN 6499-ER 32	... 000	25	47	87	65	50	47	47	47	47	52	60	72	111



ZB 655 ...*



ZB ER ...*



ZB ET ...*



ZB 741 ...*



Darstellung symbolisch
symbolical drawing
schéma symbolique

*** nicht im Lieferumfang enthalten**
not included in delivery
non compris dans la livraison

Winkel- Bohr- und Fräskopf

Radial drilling and milling head

Tête de perçage et de fraisage radiale

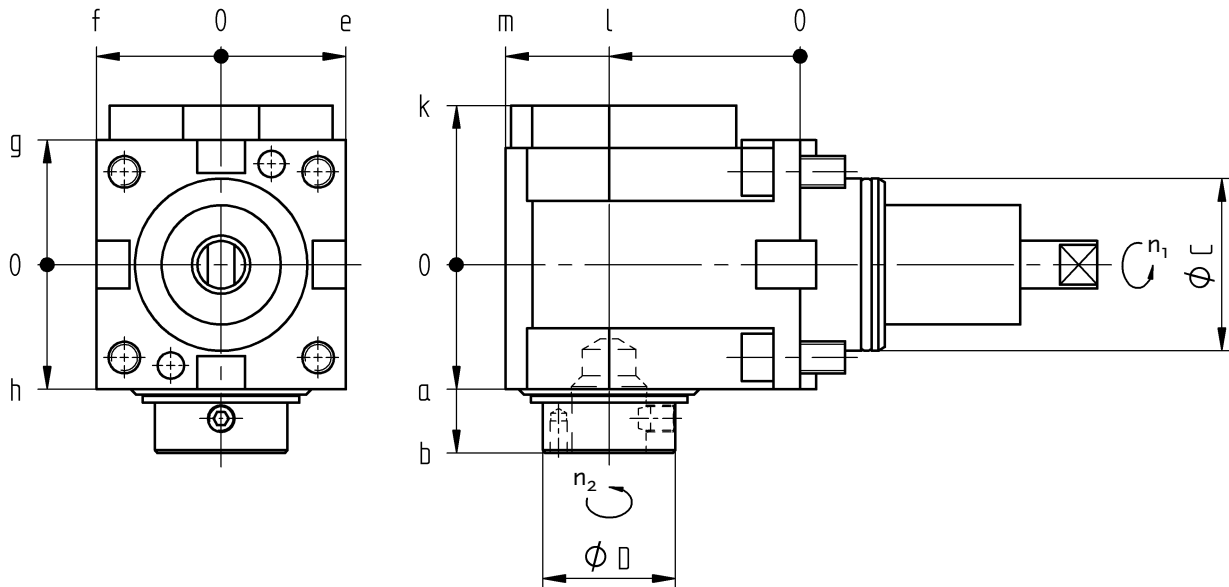

Interne Kühlmittelzufuhr: Angaben unter „IK“ in Tabelle mit Diagramm „D oo ...“ beachten
for internal coolant supply: Please note the diagram „D oo ...“ which is mentioned in the column named „IK“

pour arrosage interne: voir le diagramme „D oo ...“ mentioné dans la colonne „IK“ du tableau ci-dessous

$$i = 1 : 1$$

$$M_{\max} = 50 \text{ Nm}$$

$$n_1 = +n_2$$

$$n_{\max} = 6000 \text{ min}^{-1}$$

easy-quick

easy-quick

easy-quick

Bestell-Nr. ref.-no. no. de cde.	Werkzeugaufnahme clamping application attachment outfl	IK D oo ...	p _{max} [bar]	a [mm]	b [mm]	øC [mm]	øD [mm]	e [mm]	f [mm]	g [mm]	h [mm]	k [mm]	l [mm]	m [mm]
8 030 67 025	easy-quick HT 5	-	-	47	71	65	50	47	47	47	47	50	72	111
8 030 67 026	easy-quick HT 5	... 000	25	47	71	65	50	47	47	47	47	60	72	111



ZB 655 ...*



ZB HT ...*



Darstellung symbolisch
symbolical drawing
schéma symbolique

*** nicht im Lieferumfang enthalten**
not included in delivery
non compris dans la livraison

Legende







Legend
Légende

Symbolbeschreibung

description of symbol

table des symboles



Symbole symbols symbole	Zubehörblatt accessory sheet accessoires
 ZB 655 ...	Bedienwerkzeuge service tools clés de serrage
 ZB ER ...	Spannzangen ER – DIN 6499 collets ER – DIN 6499 pince de serrage ER – DIN 6499
 ZB ET ...	Gewindebohrzangen ET – DIN 6499 tapping collet ET – DIN 6499 pince de taraudage ET – DIN 6499
 ZB 741 ...	Dichtscheiben sealing disks joints d'étanchéité
 ZB 771 ...	Mitnehmer für Gewindebohrer drivers for tap les entraîneur pour taraud
 ZB 620 ...	Fräsdornringe milling arbor spacers bagues de réglage fraise
 ZB HT ...	<i>easy-quick</i> System <i>easy-quick</i> system <i>easy-quick</i> système



Darstellung symbolisch
symbolical drawing
schéma symbolique